



← THE →
Farmer's Wife
SAMPLER QUILT



*Letters from
1920s farm wives
AND THE
111 blocks they inspired*

LAURIE AARON HIRD

R E A D M E

THE
Farmer's Wife
SAMPLER QUILT

Letters from 1920s farm wives and the 111 blocks they inspired

Copyright © 2009 by Laurie Aaron Hird. All rights reserved. The author and publisher of this book give permission to print and use designs for personal use only. Office supply stores are granted the right to print up to five (5) copies of each template for their customers' personal use.

PRINTING:

If the templates are printing at a size that does not result in a 6" block, check your printer settings. The setting should be 100% or "actual size." Scaling should be "none." Sometimes printers will default to "reduce to fit" or "fit to page," which will result in templates being printed at the wrong size. You may also find it helpful to set your printer margins at 0, so the printer has the full page on which to print. The four quilt assembly diagrams are for reference only and can be printed at any size.

ABOUT THE TEMPLATES:

You can mix, match and reuse these 106 individual templates to create the 111 blocks featured in *The Farmer's Wife Sampler Quilt*.

We suggest printing out each template and keeping it in a three-ring binder. From your printouts, create templates by tracing the shapes onto template plastic (for the most used templates) or cardboard (empty cereal boxes work well). Cut out the shapes, write the template number on the plastic or cardboard with a permanent marker, and store them in a zippered plastic bag, storing 10 or so templates in each bag. This way your templates will be reusable and ready whenever you need them.

We do not recommend photocopying the printed templates, as this may result in distortion of the shapes.

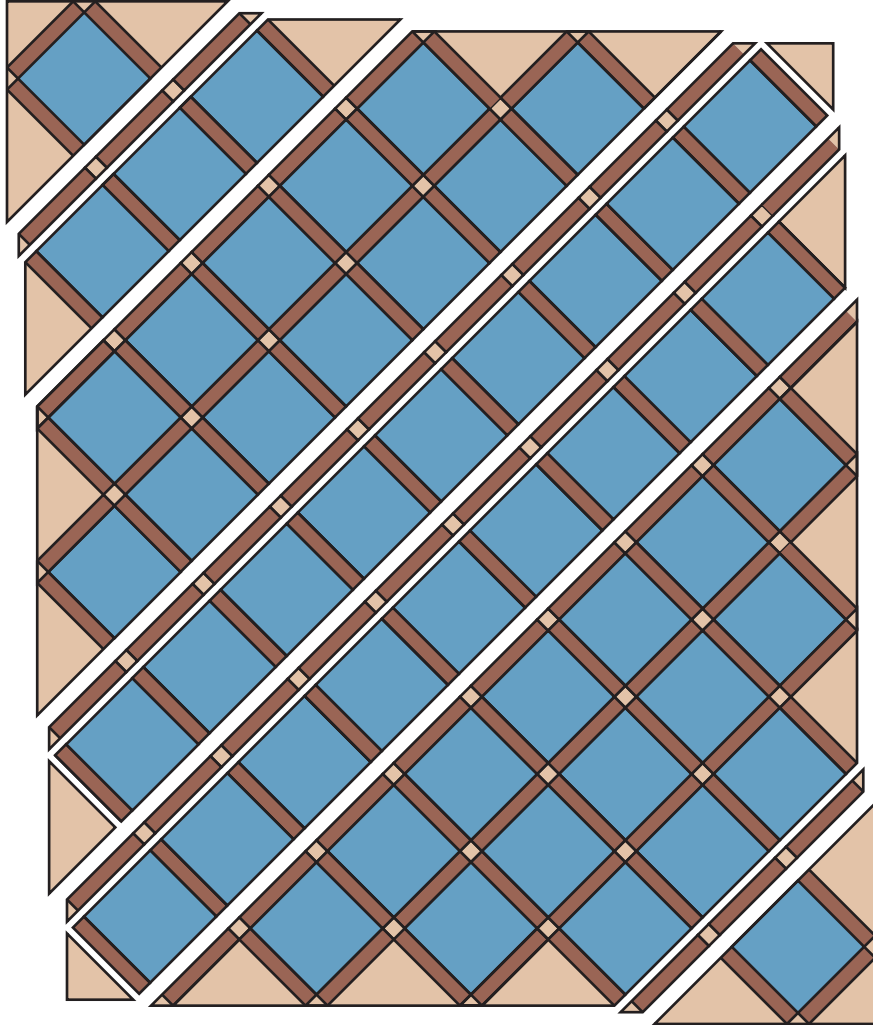

Lap-Size Quilt Assembly

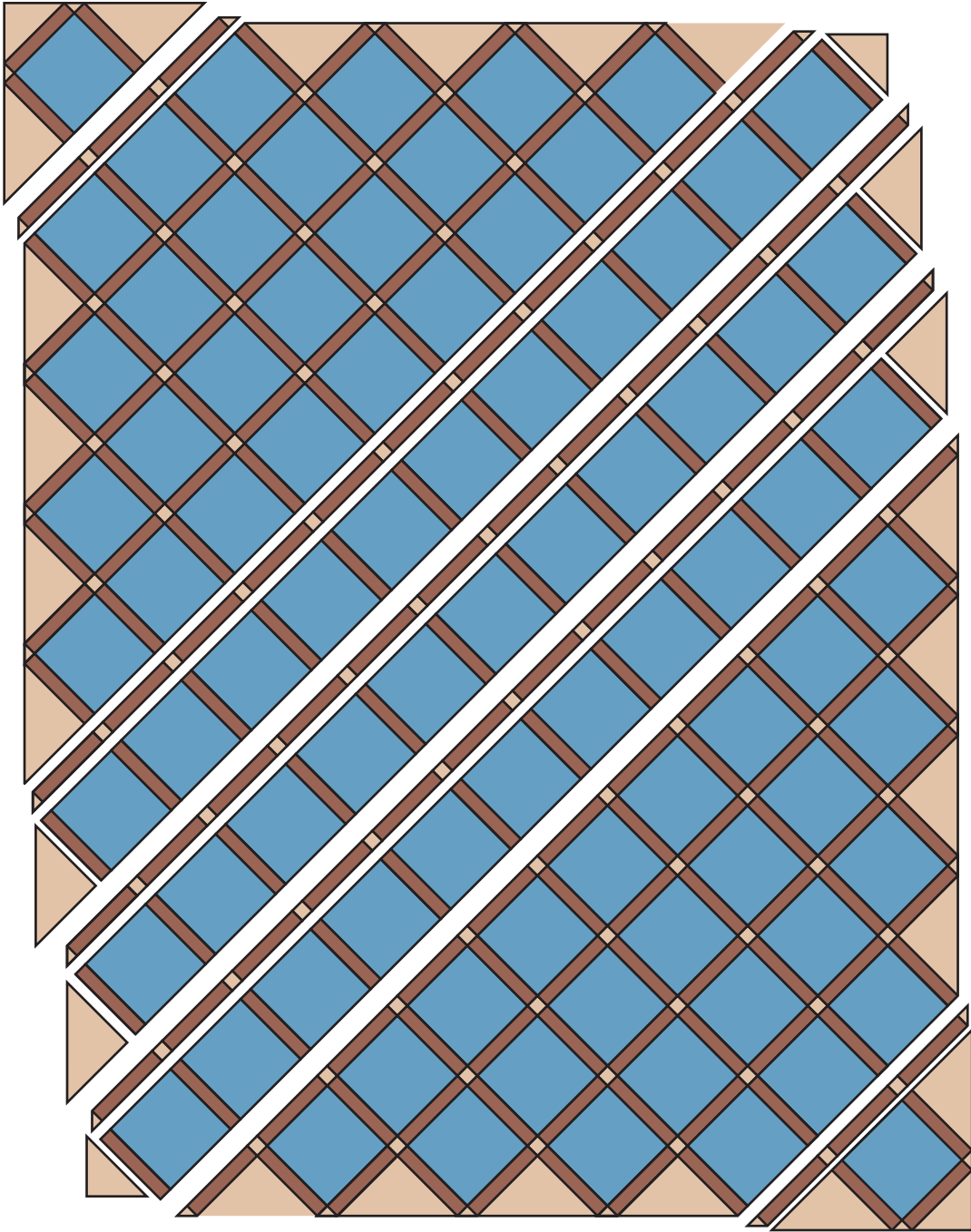

Twin-Size Quilt Assembly

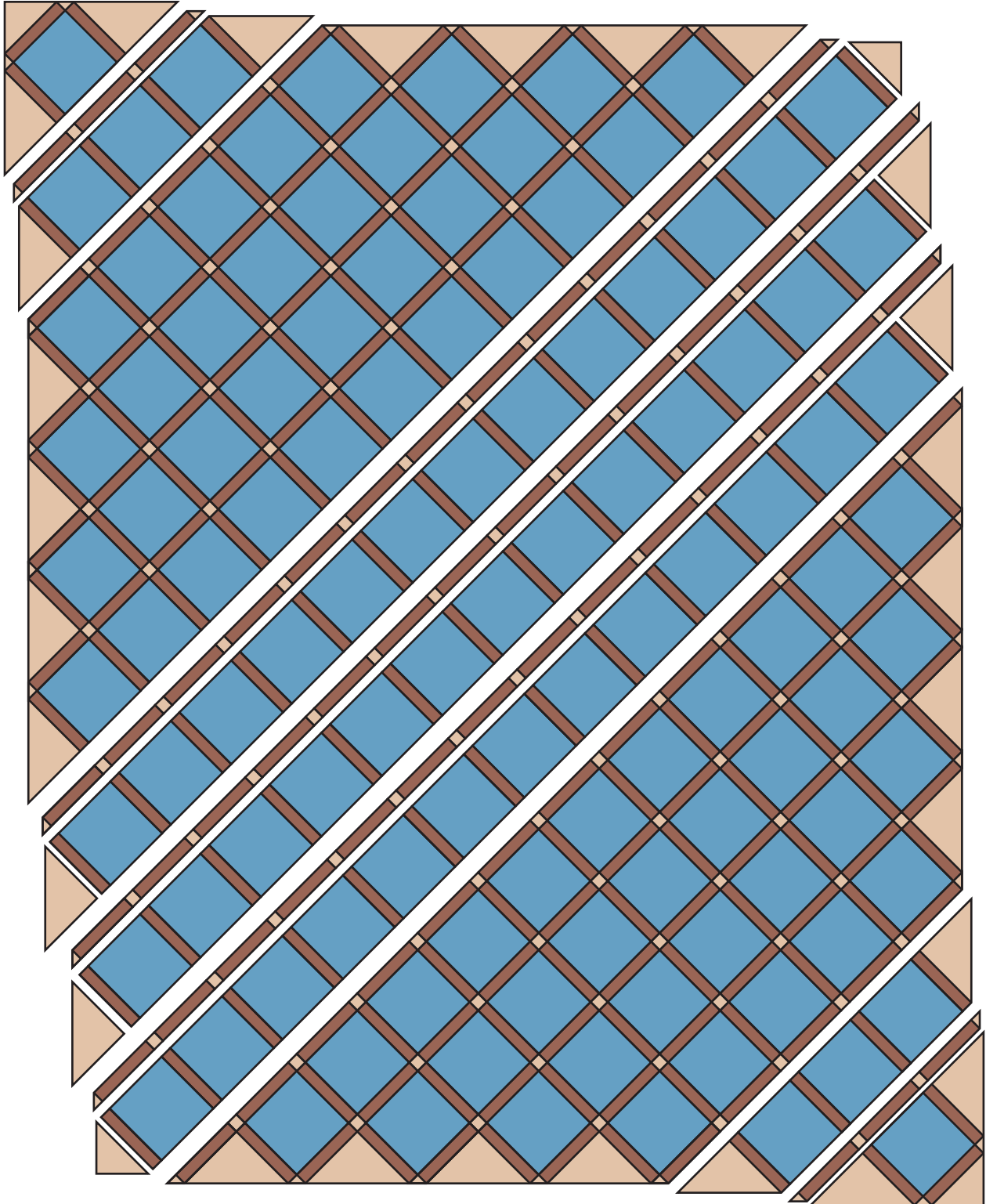

Queen-Size Quilt Assembly

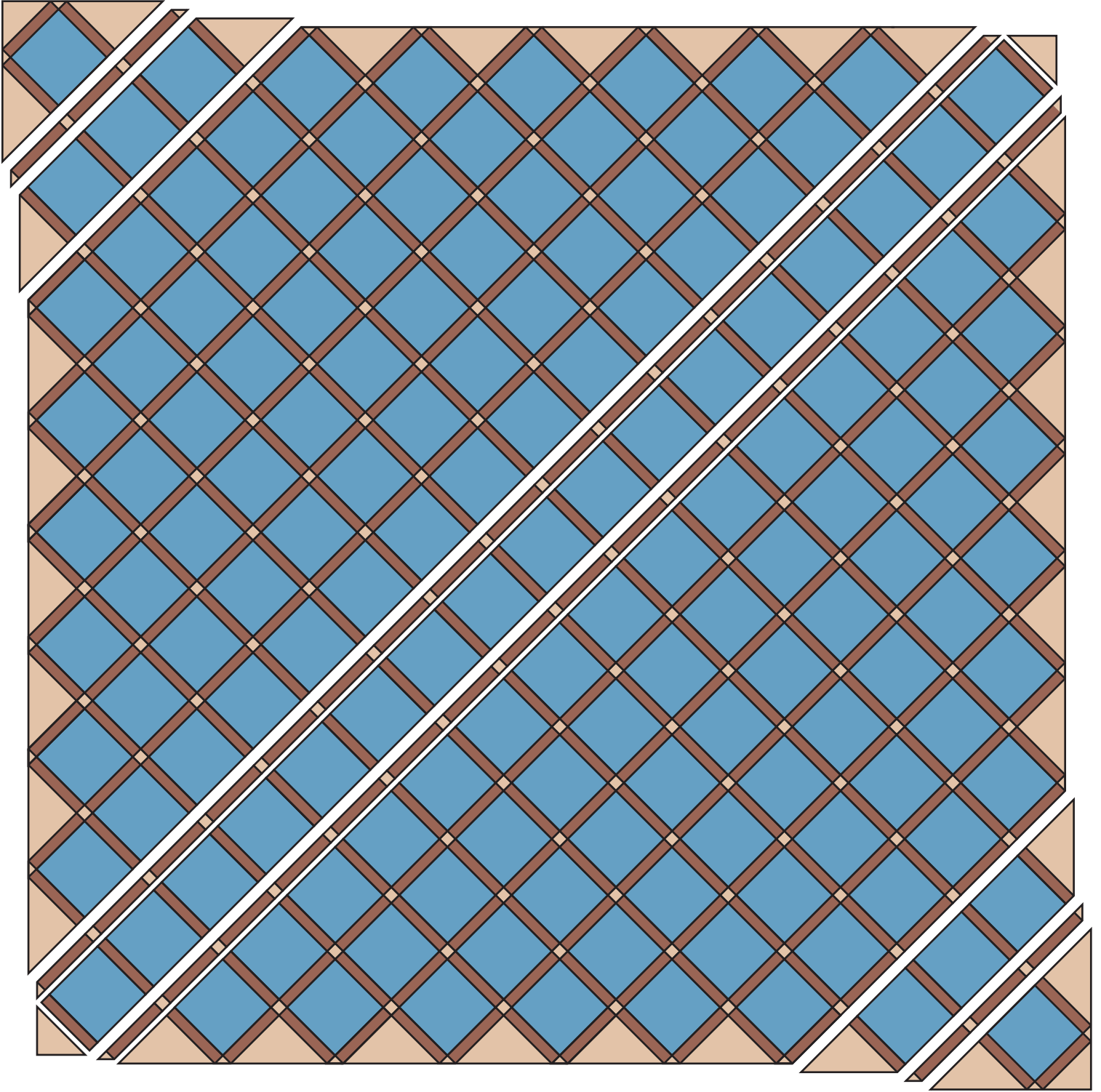

King-Size Quilt Assembly



template 1

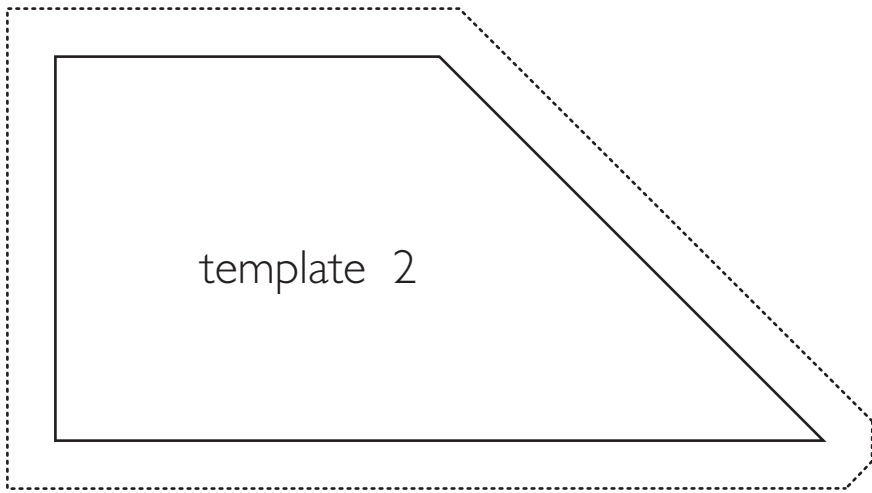

template 2

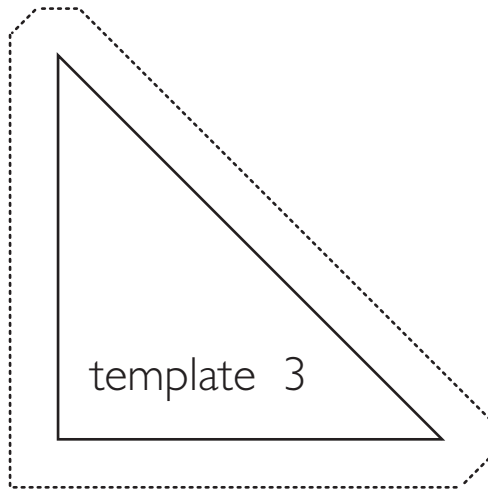

template 3



template 4



template 5

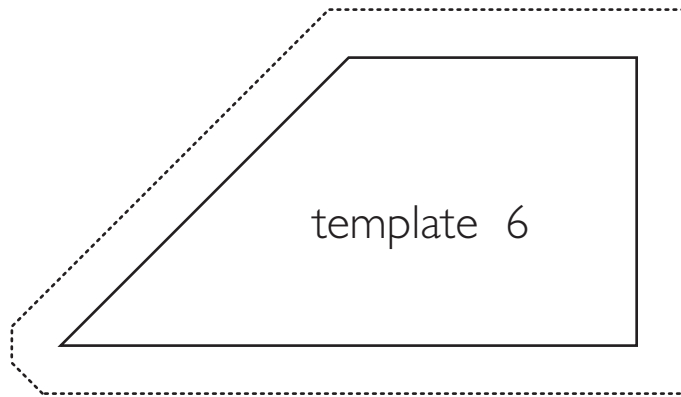

template 6

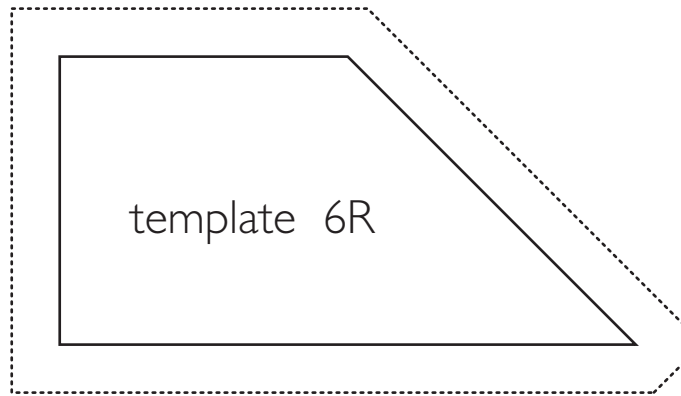

template 6R

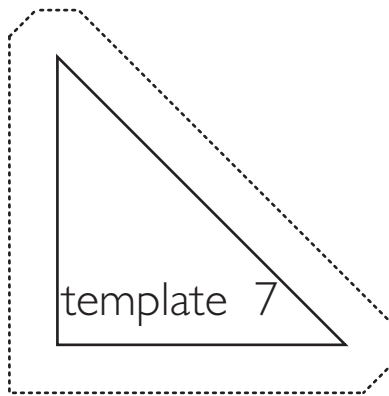

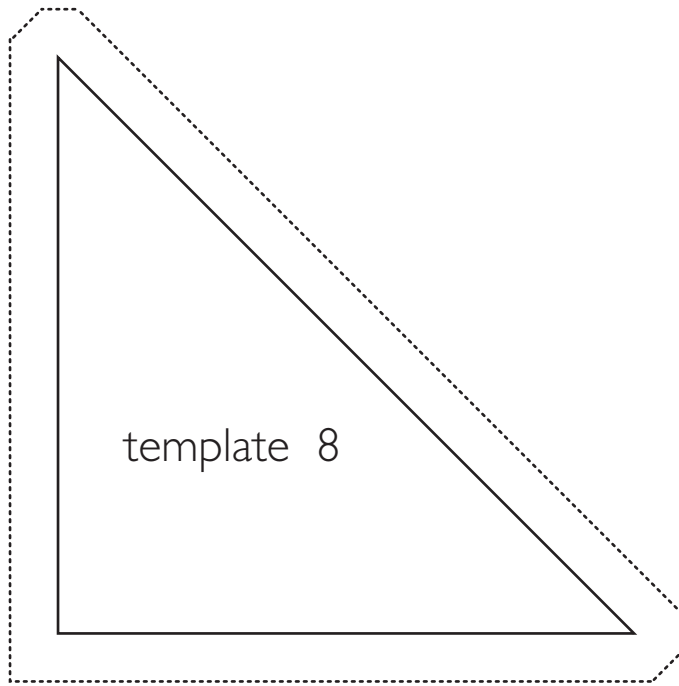

template 8



template 9

$\frac{3}{16}$ " turn-under allowance

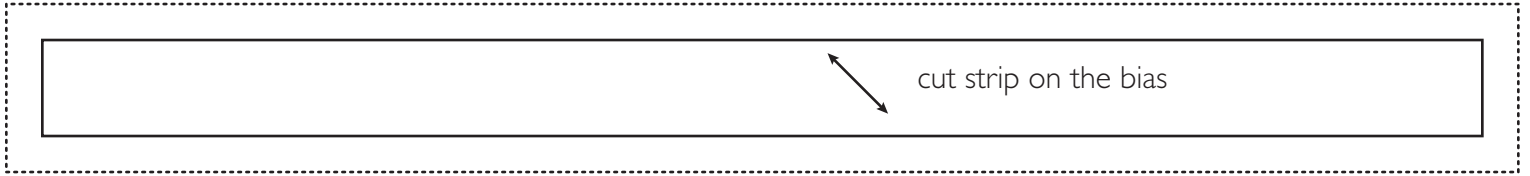

Template for hand-appliqué handle on block #3 Basket. Cut one.

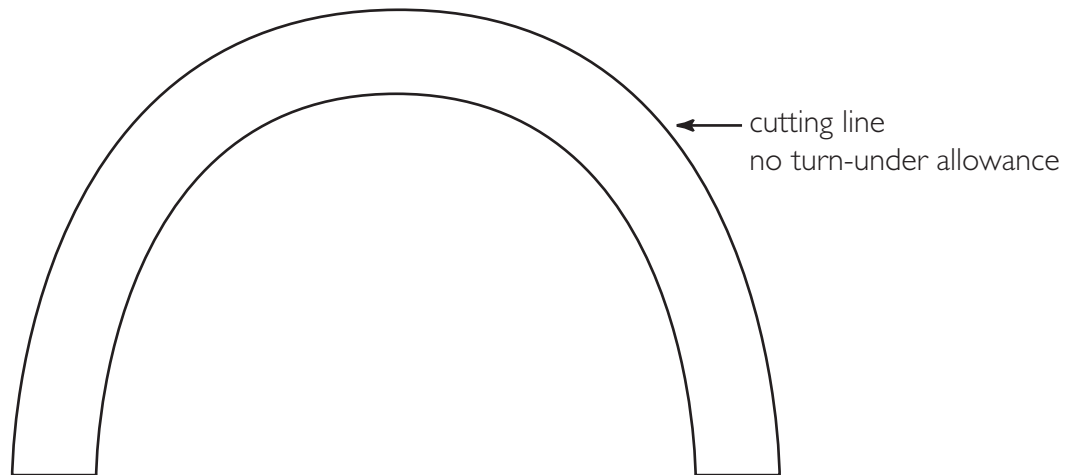

Template for machine-appliqué handle on block #3 Basket. Cut one.

template II

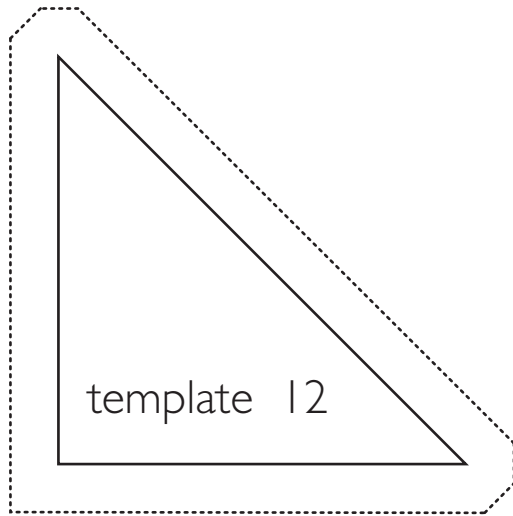

template 12

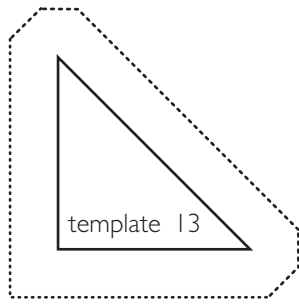

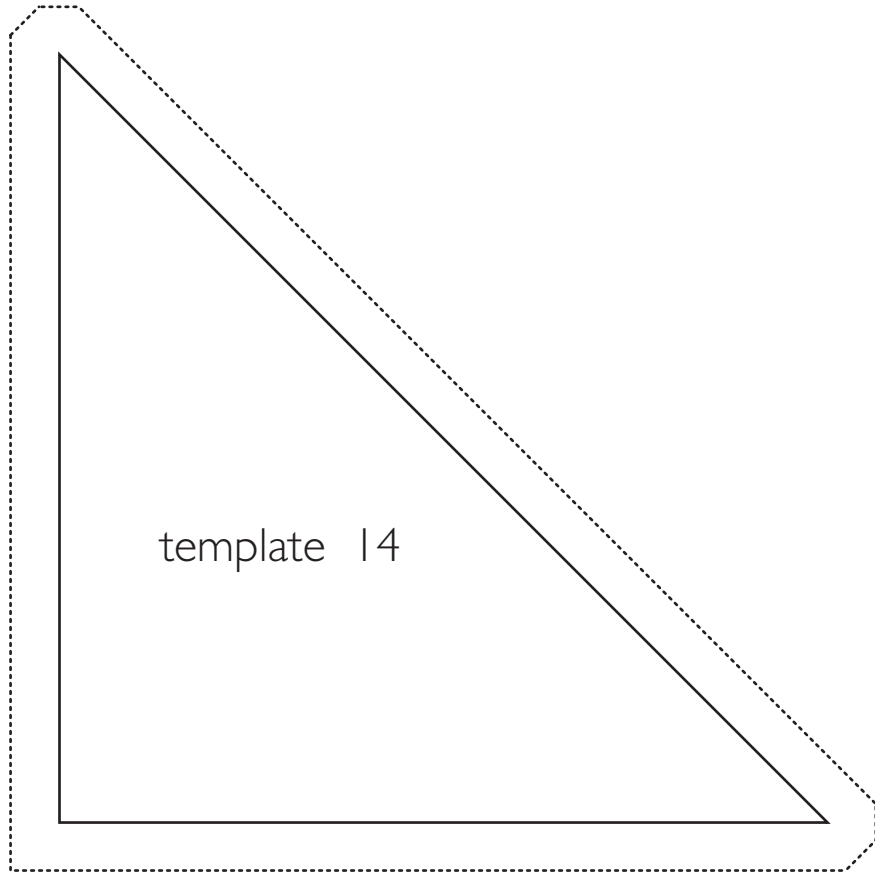

template 14

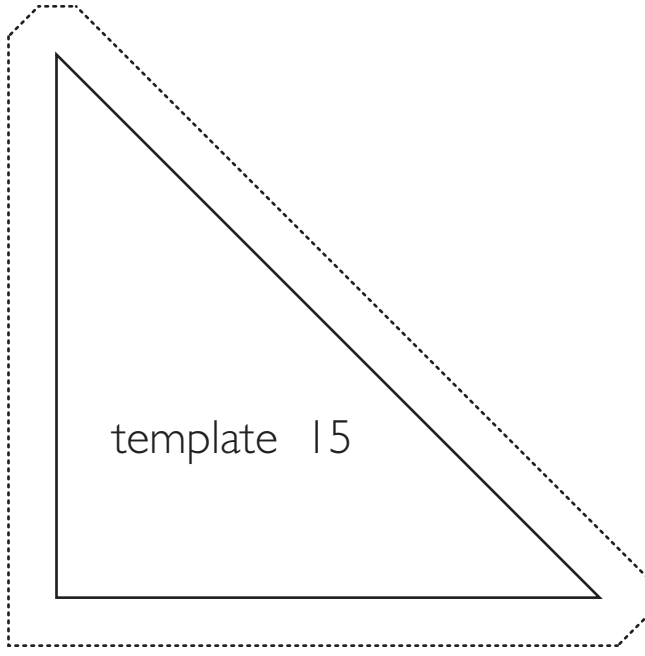

template 15

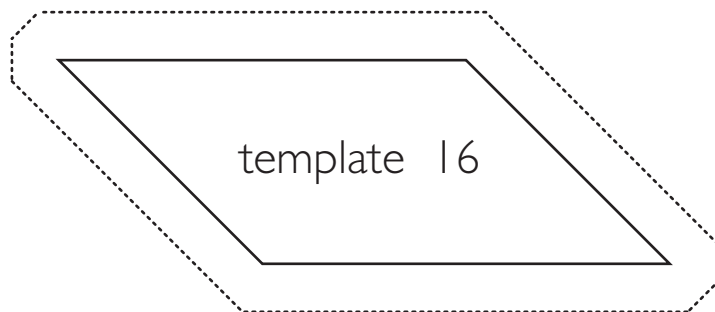

template 16

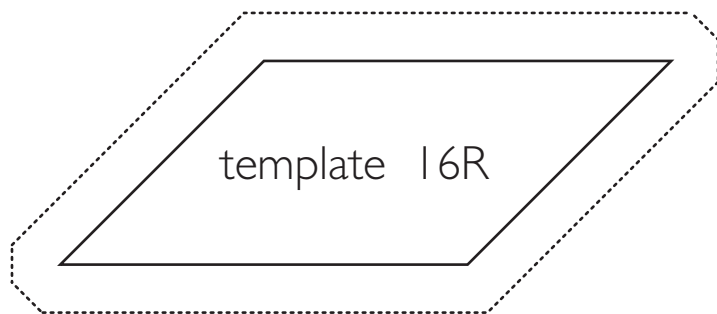

template 17

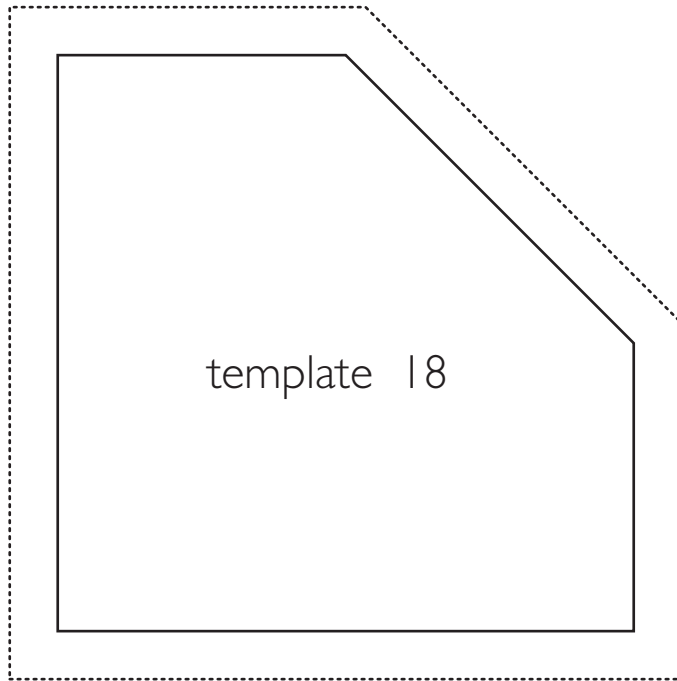

template 18

template 19

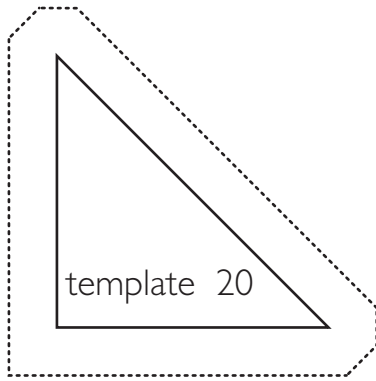



template 21

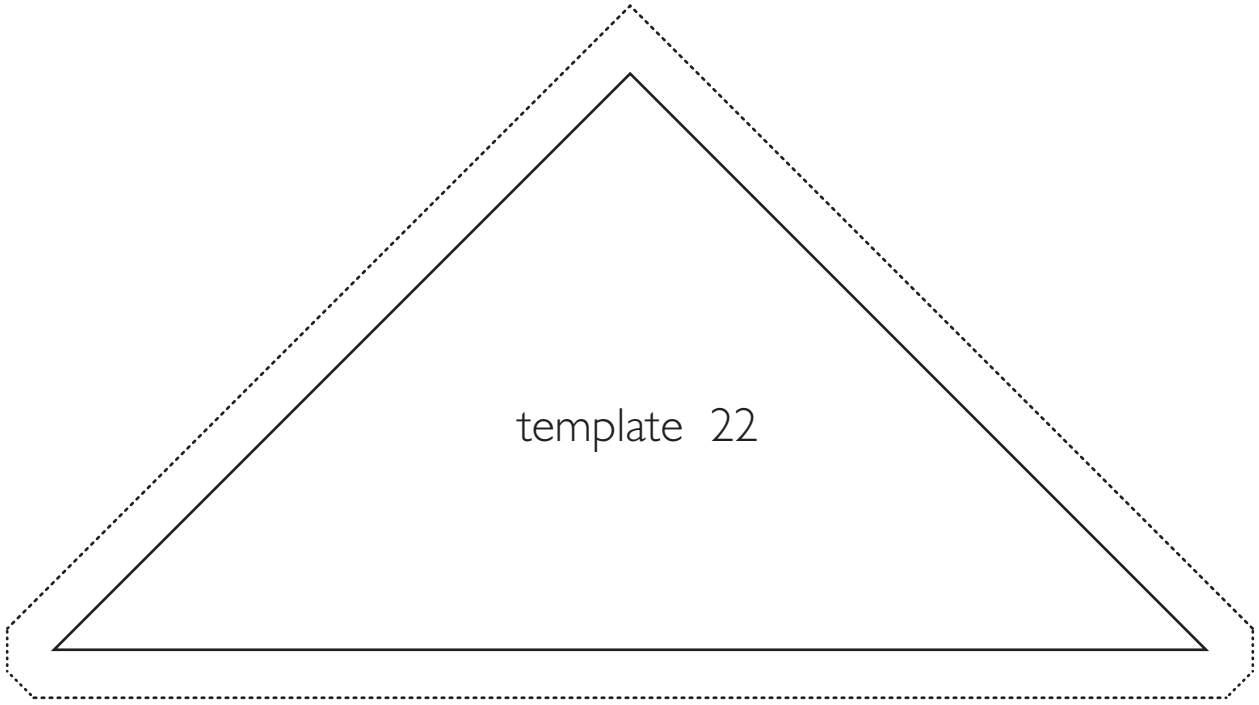

template 22

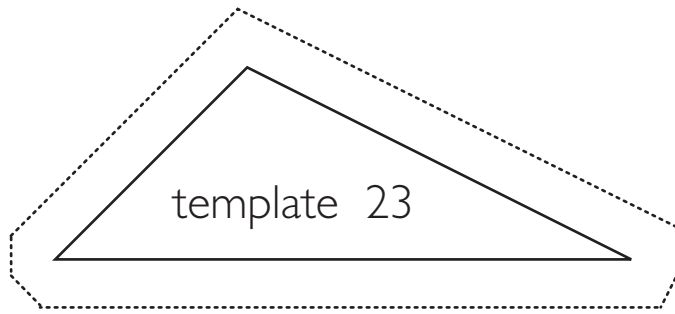

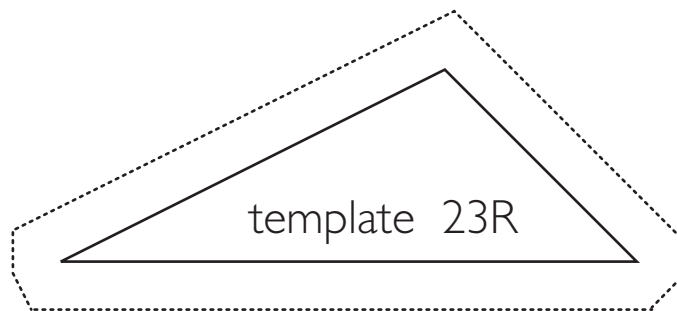

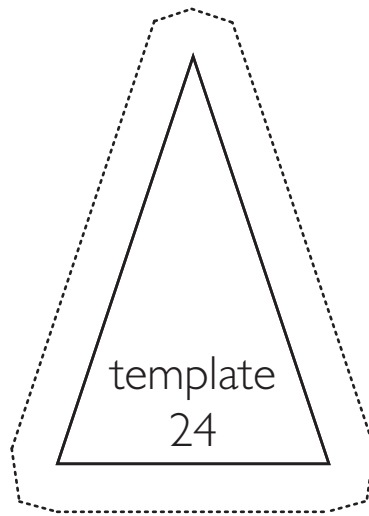

template
24

template 25

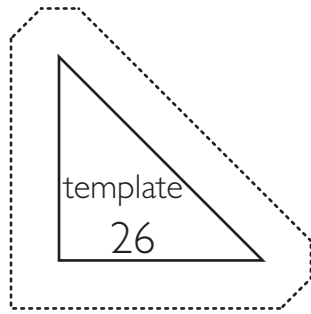

template 27

template 28

template 29

template 30

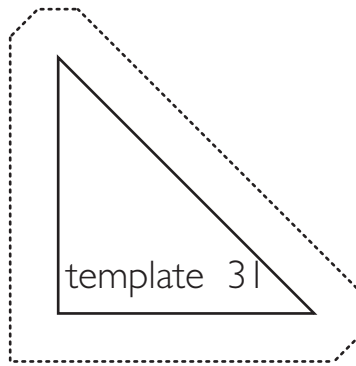

template 31

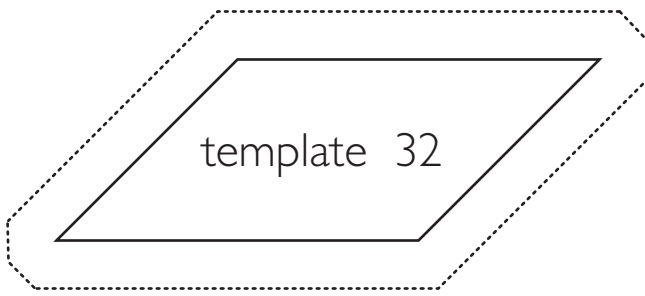

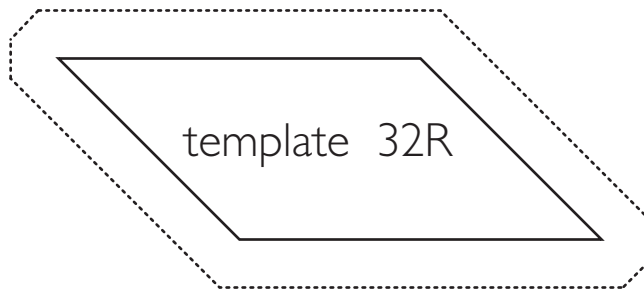

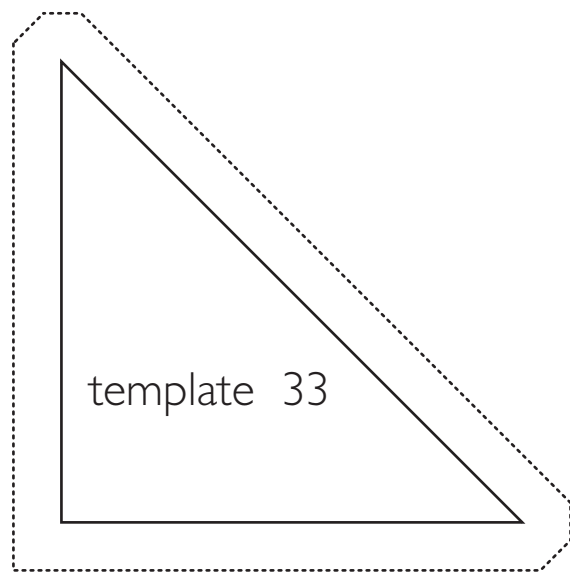

template 33



template 34

template 35

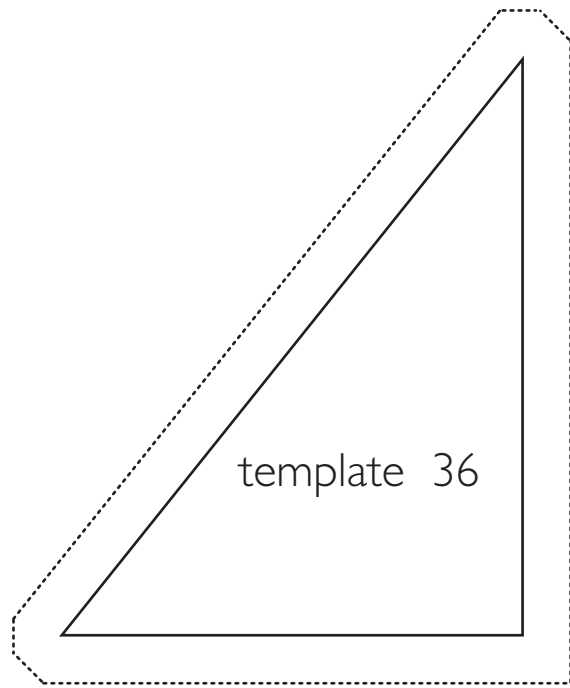

template 36

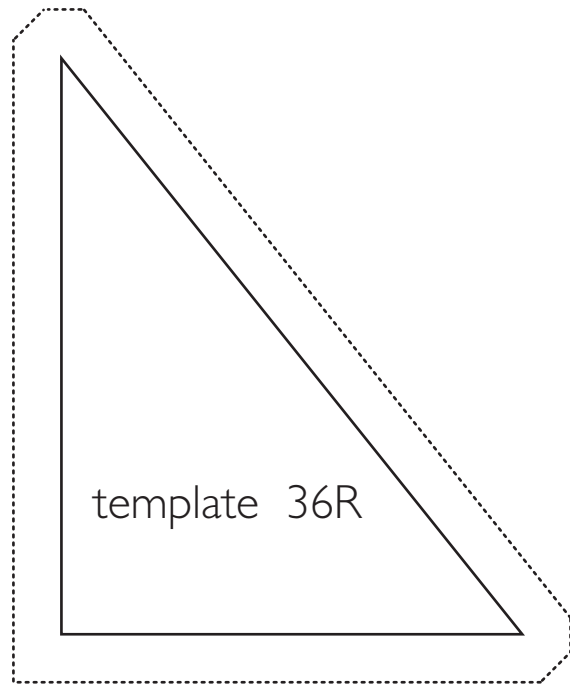

template 36R

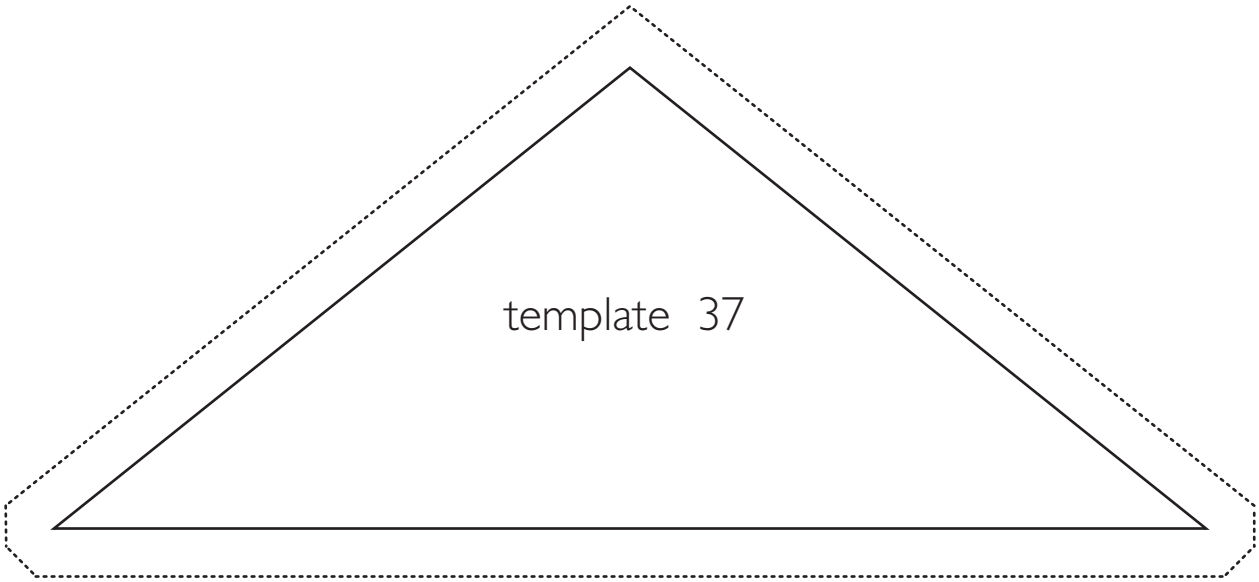

template 37

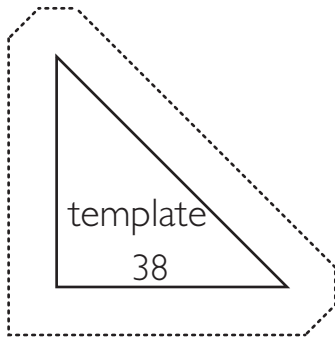

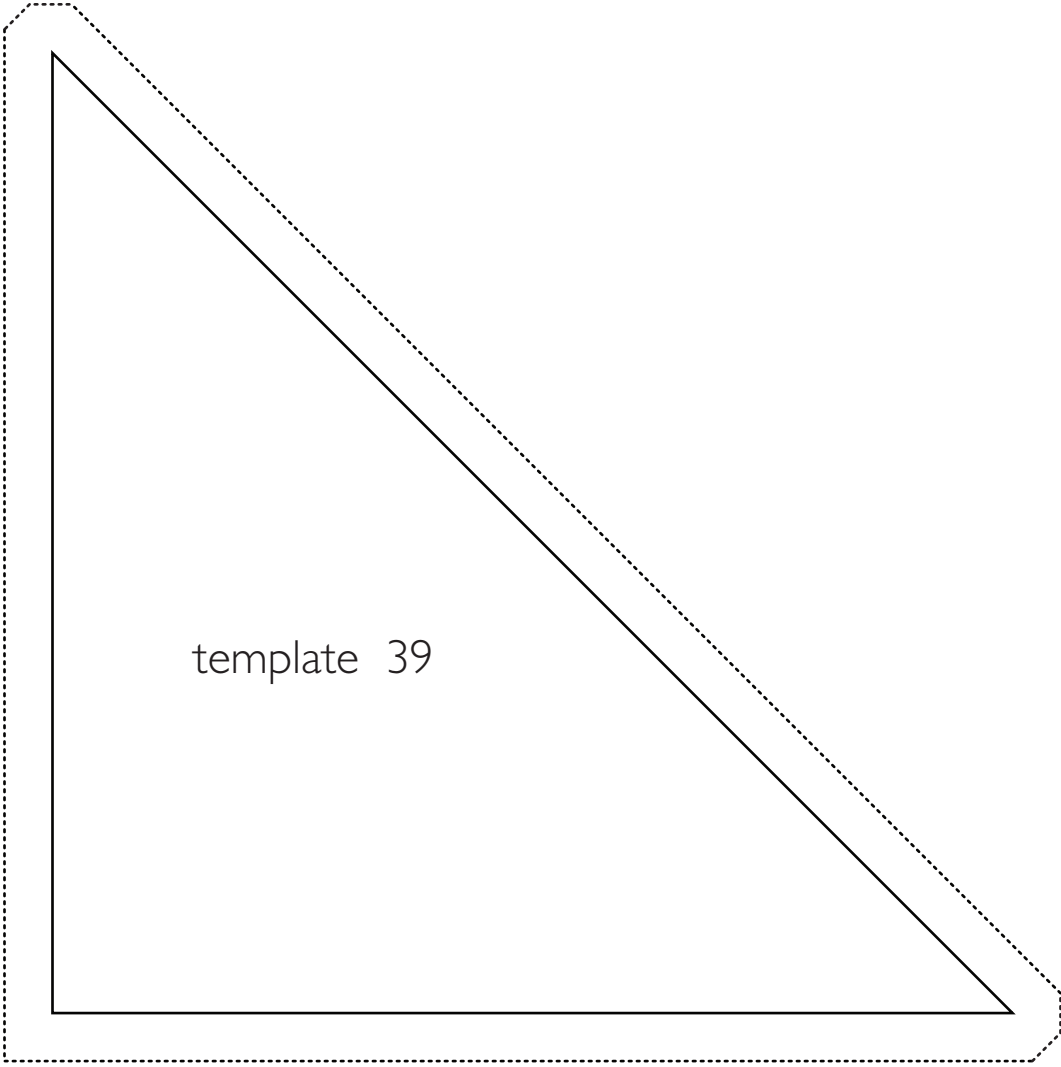

template 39

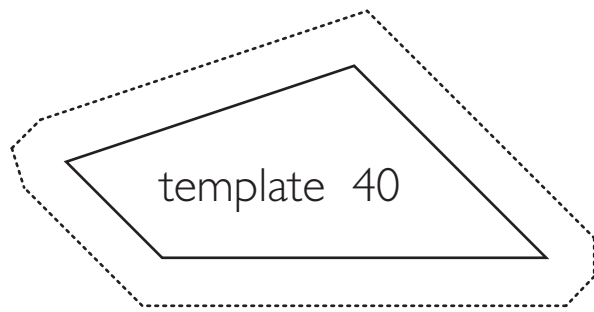

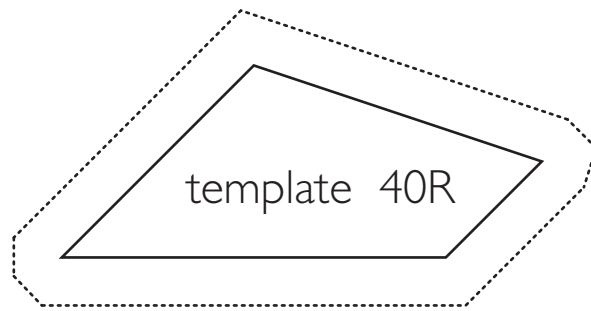

template 40R

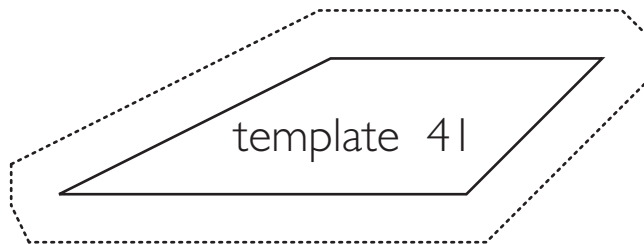

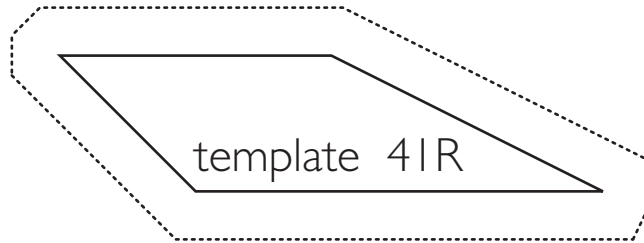

template 42

template
43

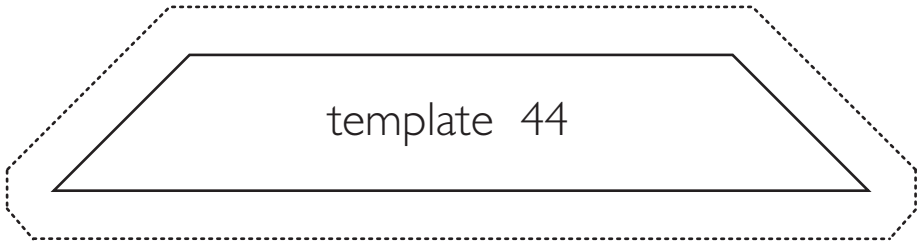

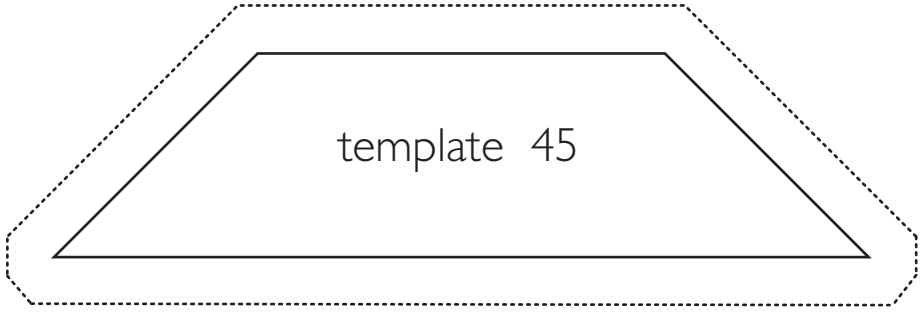



template 46



template 46R

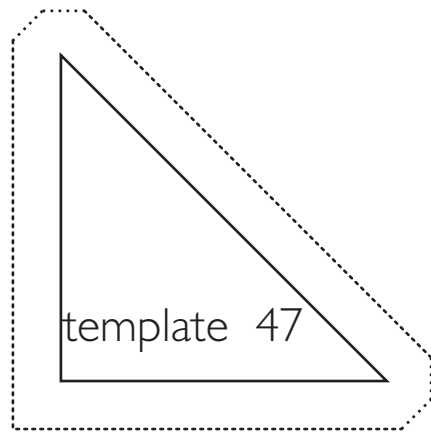

template 48

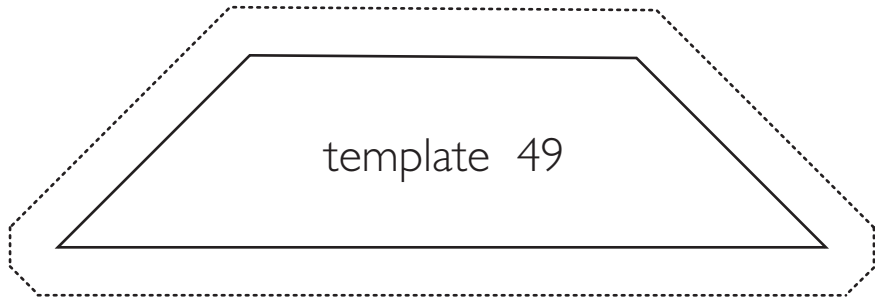

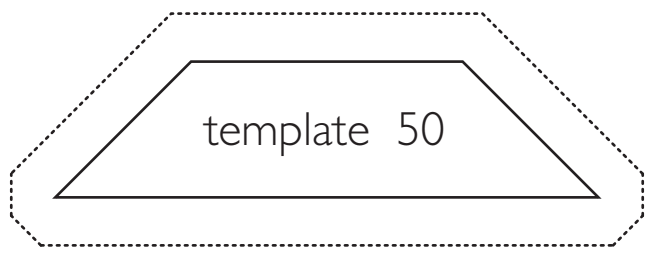

template 50

template 51

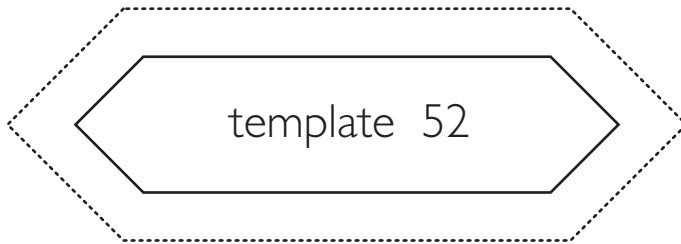

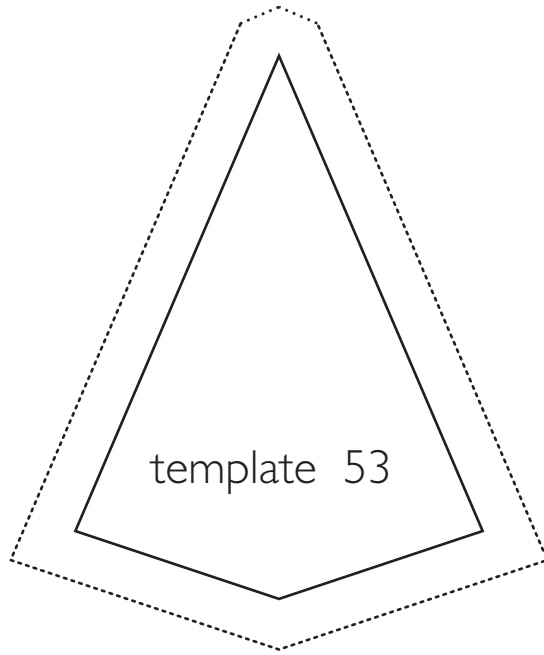

template 53

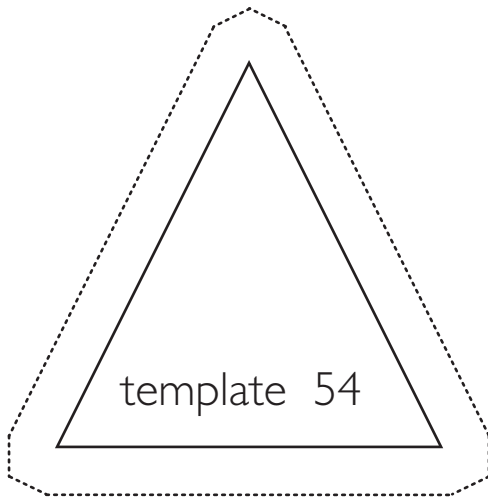

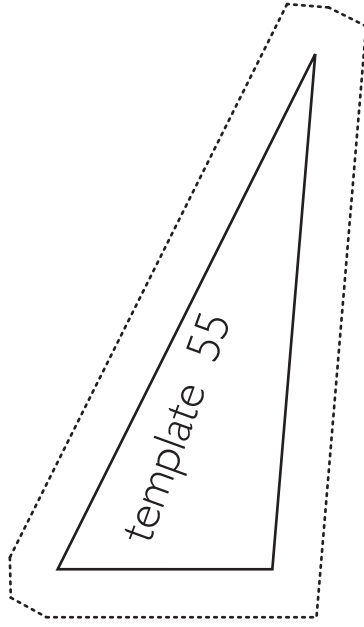

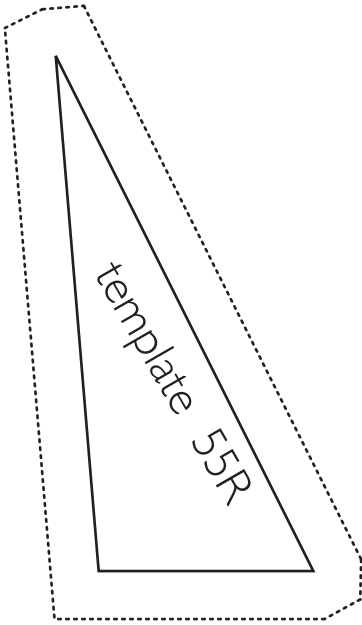

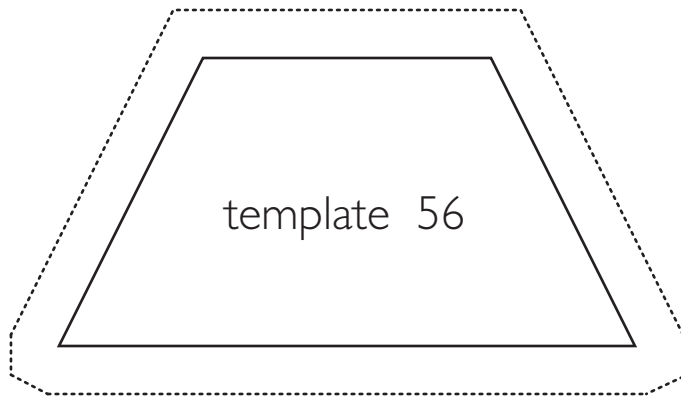

template 56

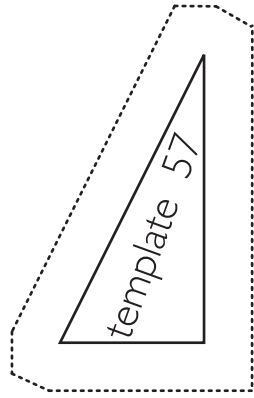

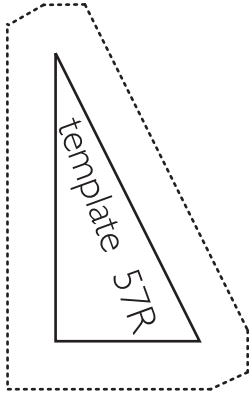

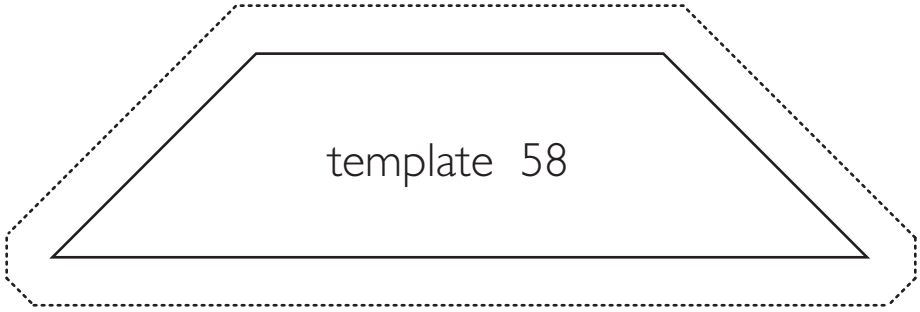

template 59



template 60

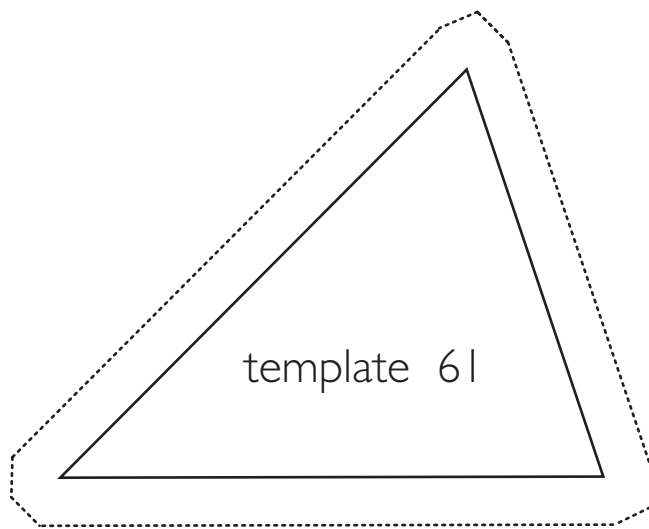

template 61

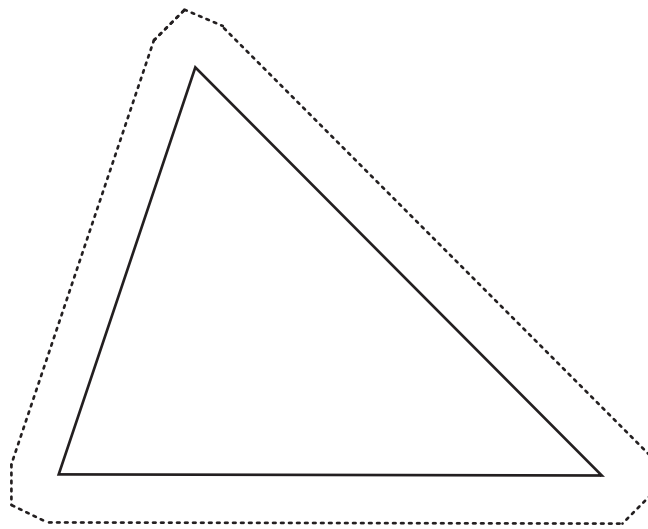

template 6IR

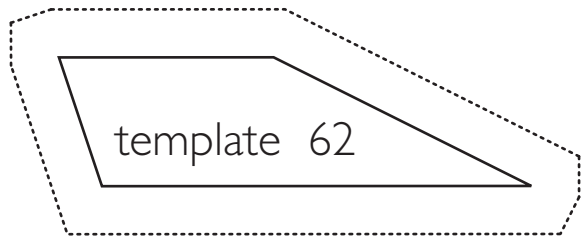

template 62

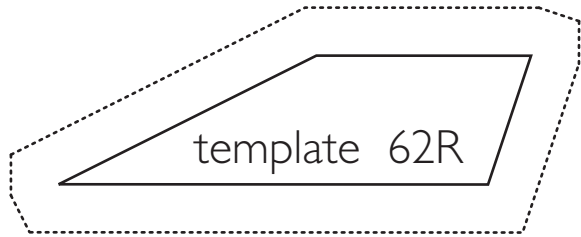

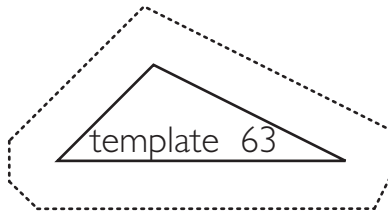

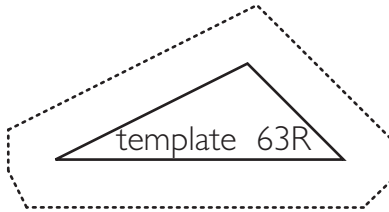

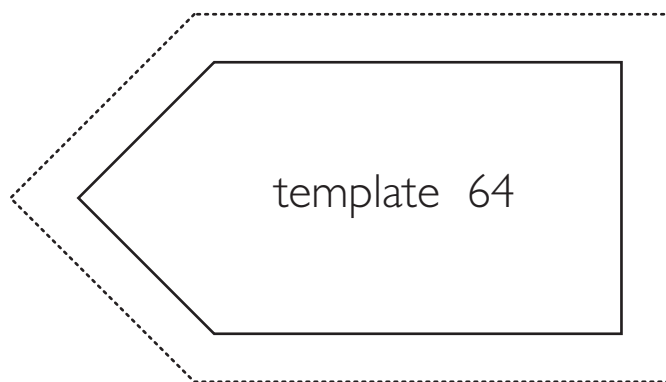

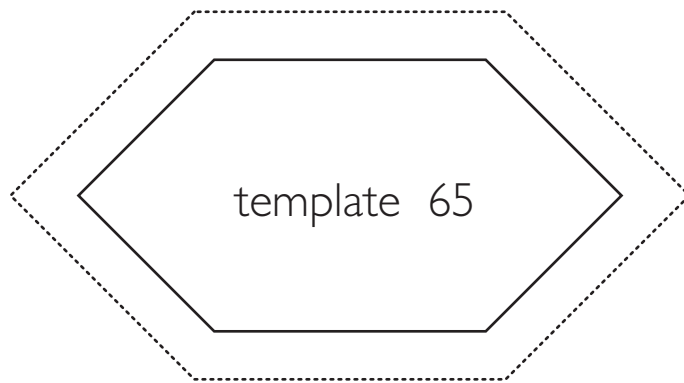

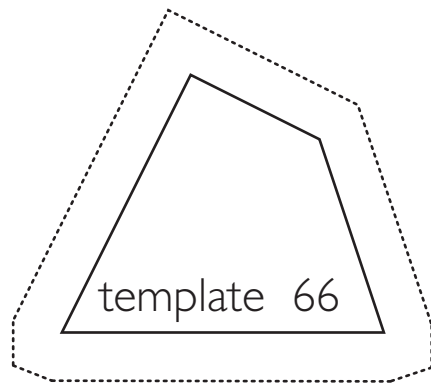

template 66

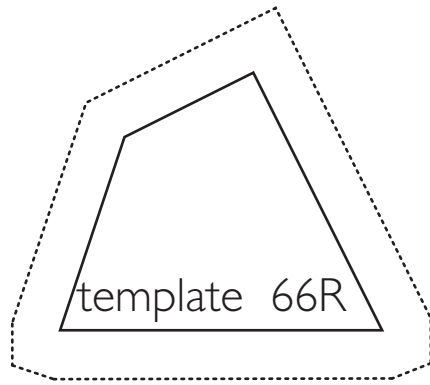

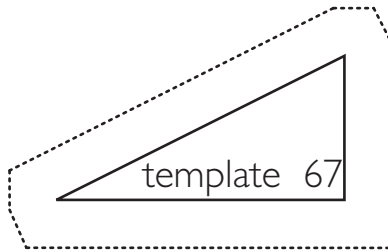

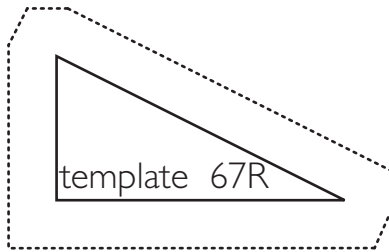

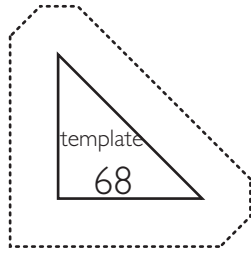

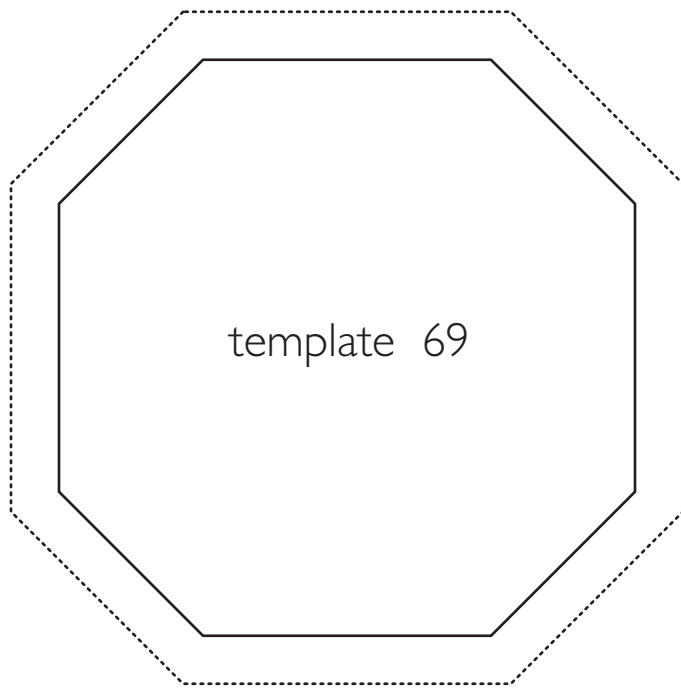

template 69

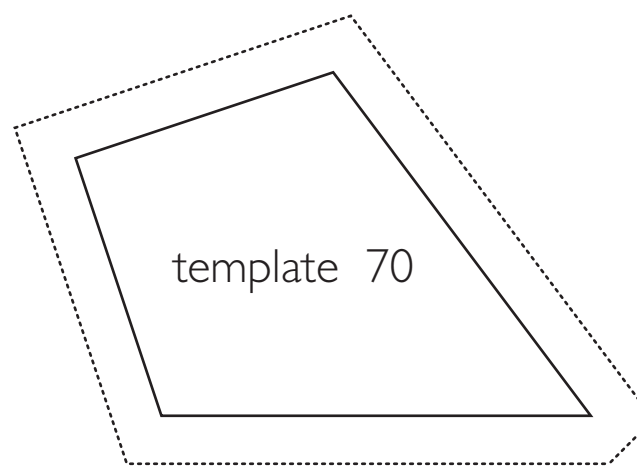

template 70

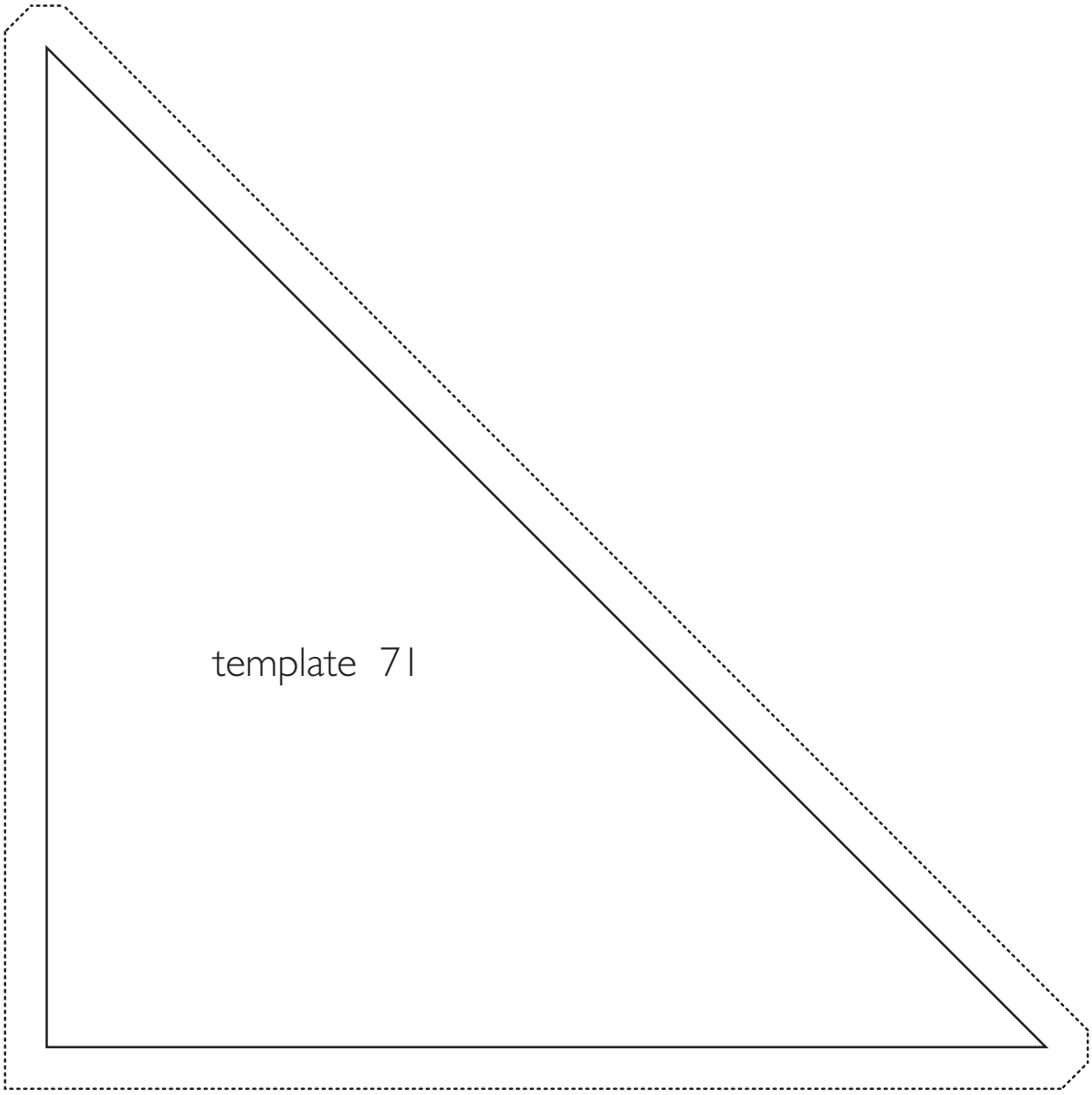

template 71

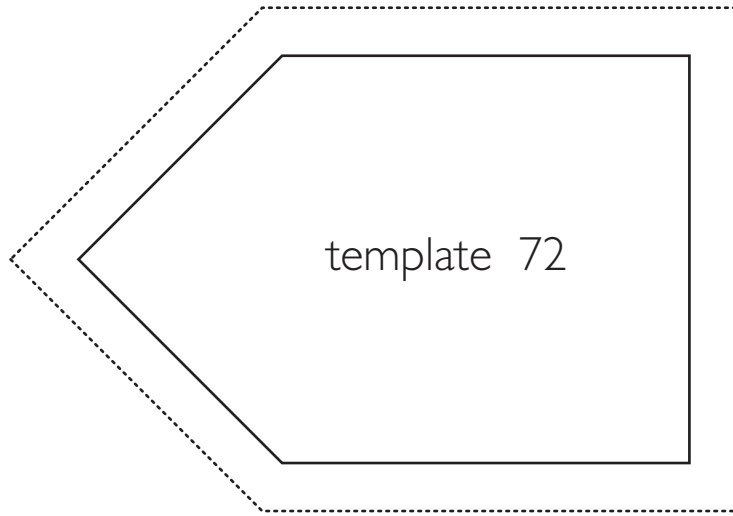

template 72



template 73

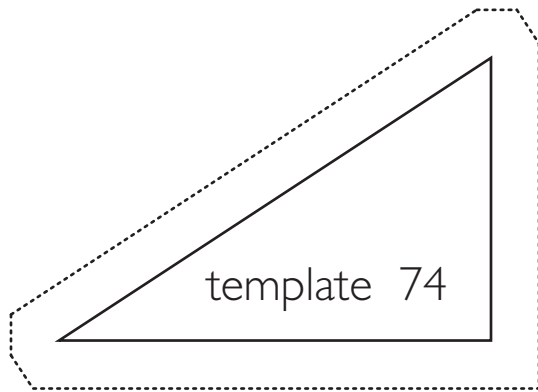

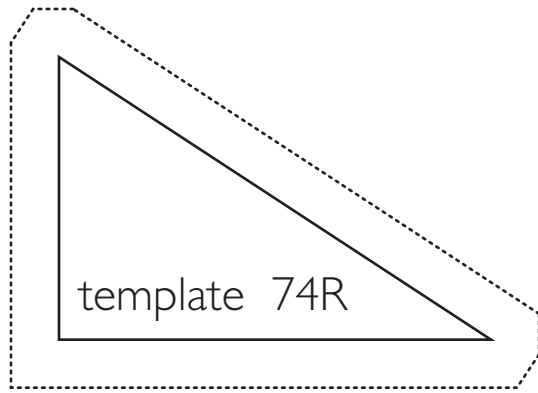

template 75

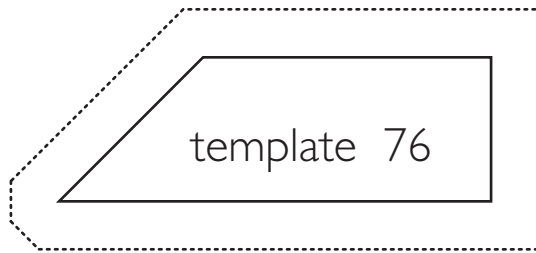

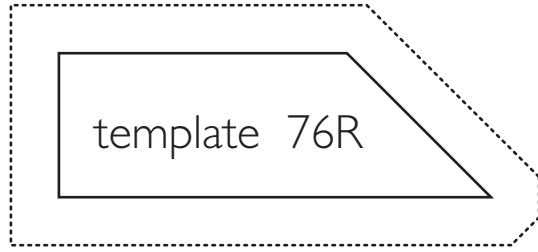

template 76R

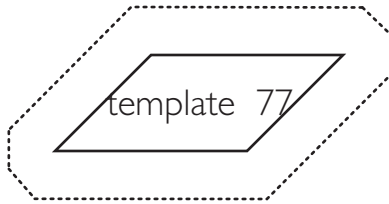

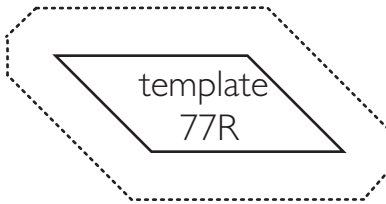

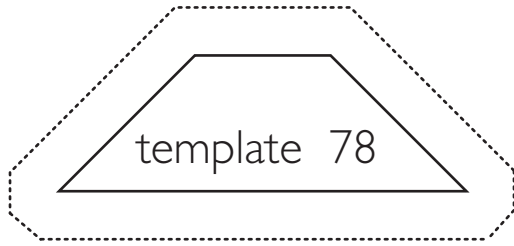

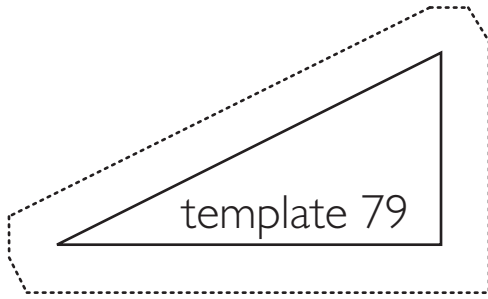

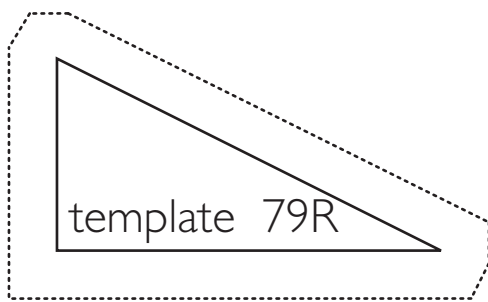

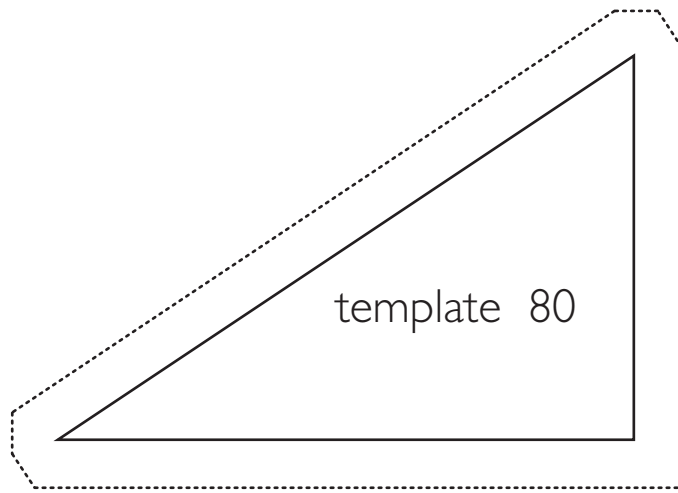

template 80

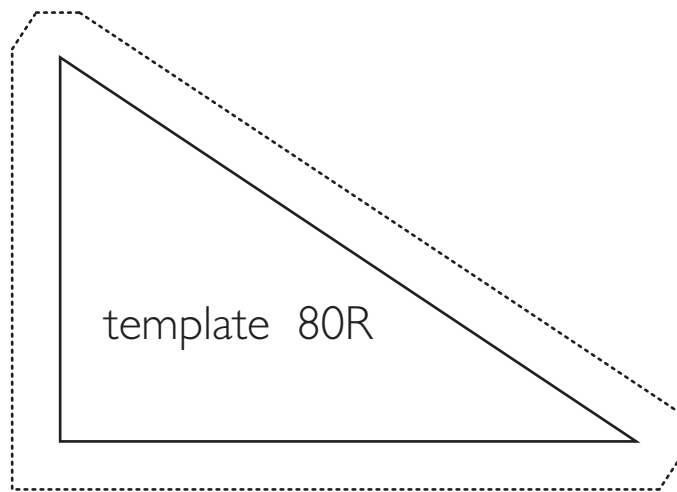

template 80R

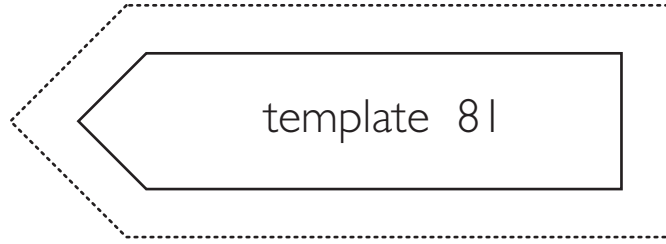



template 82

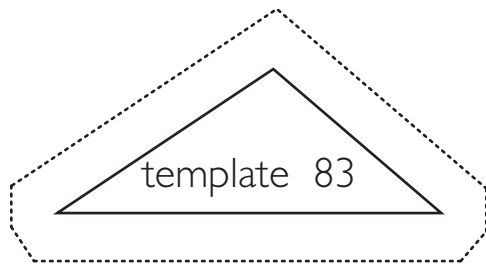

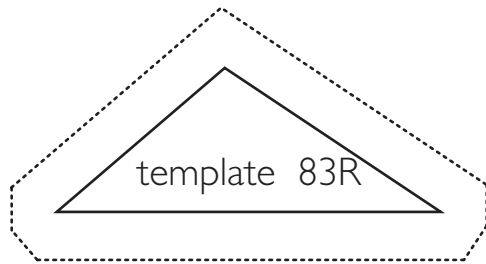

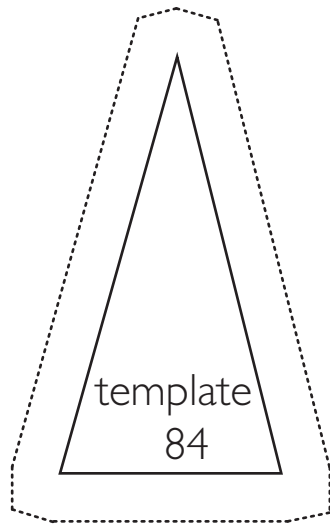

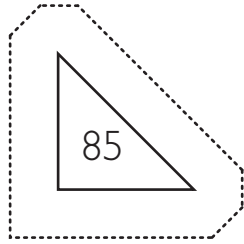

template 85

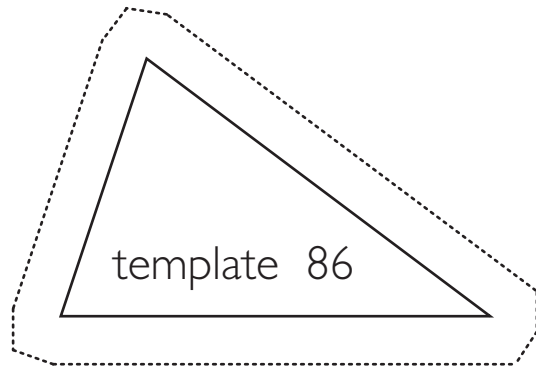

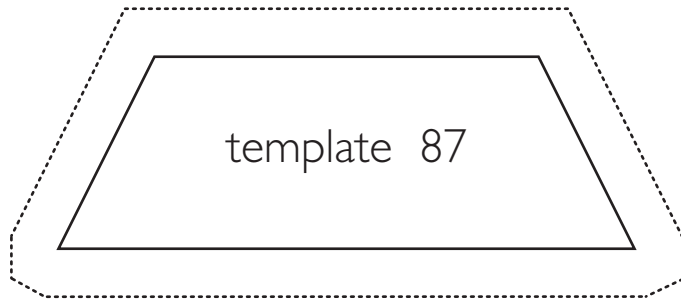

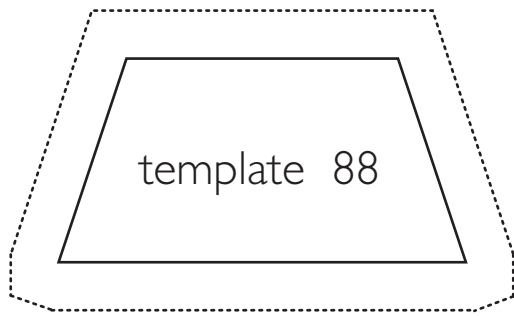

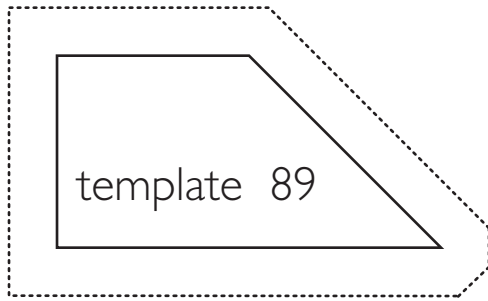

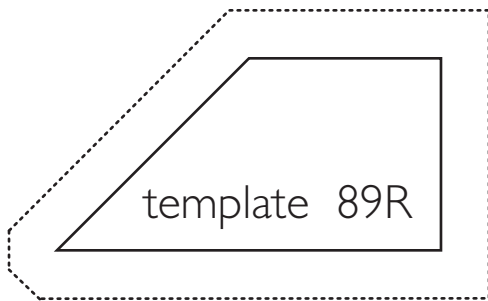

template 89R

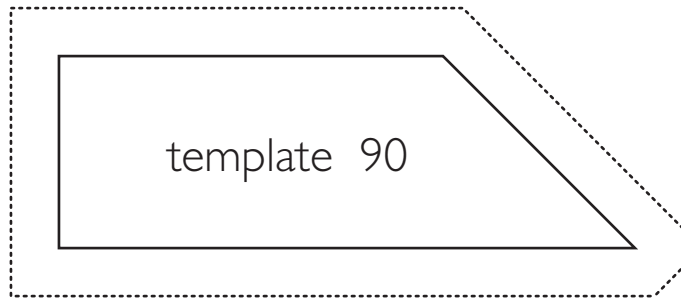

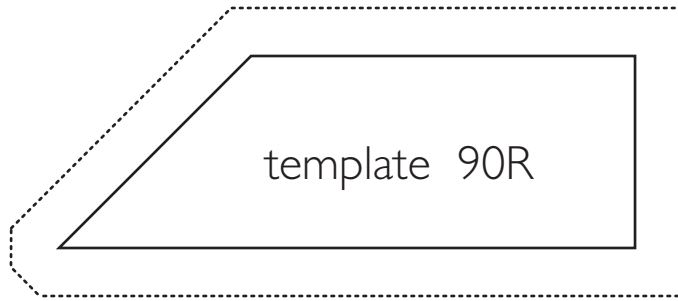

template 90R

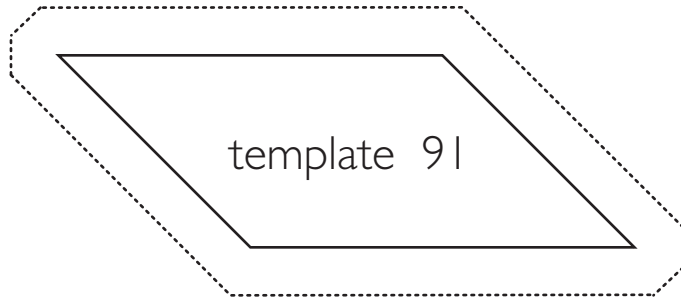

template 91

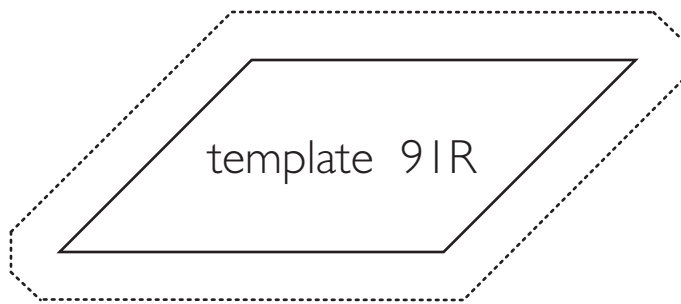

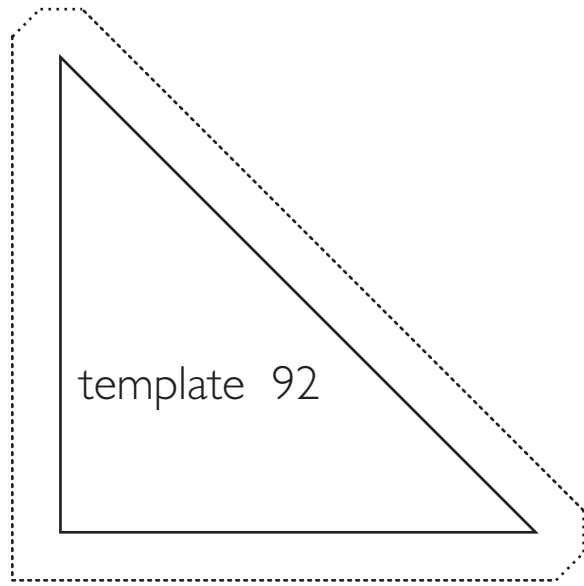

template 92

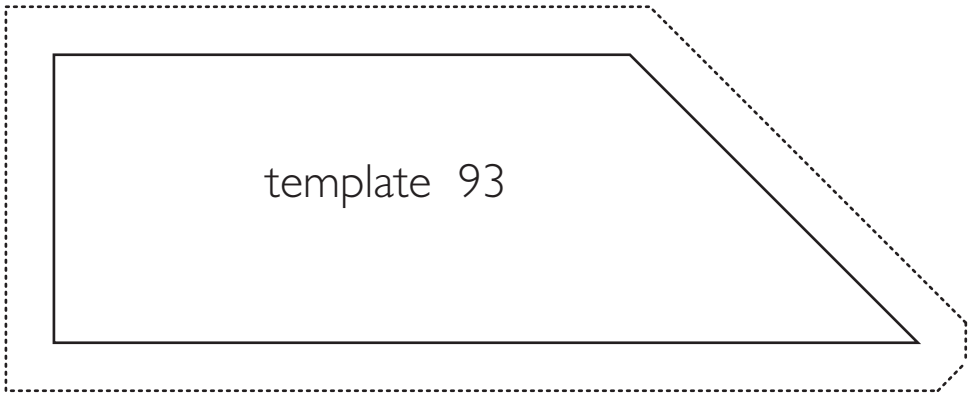

template 93

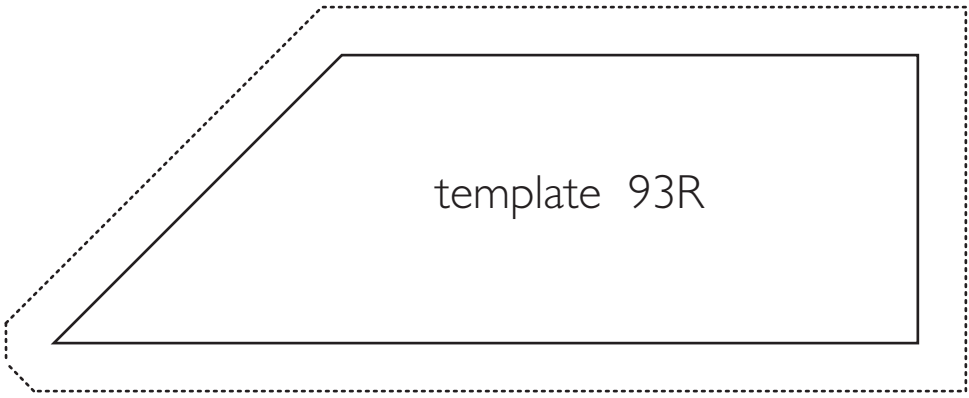

template 93R

template 94

template 95

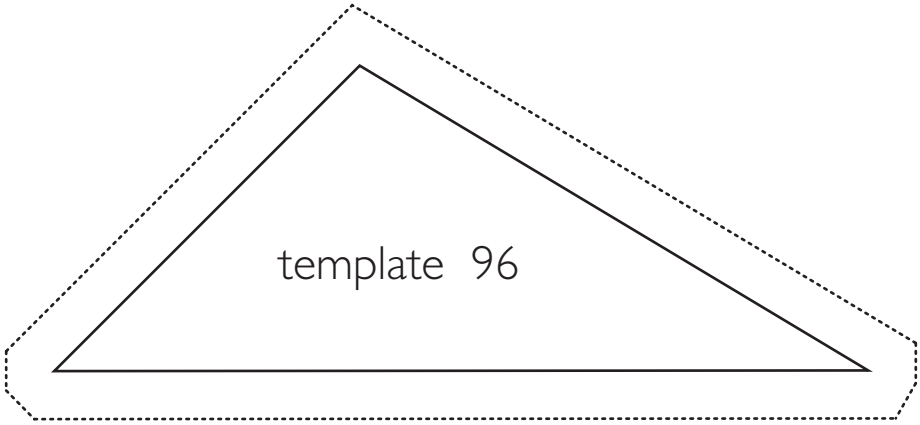

template 96

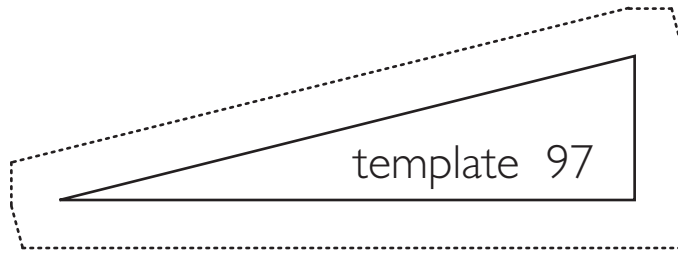

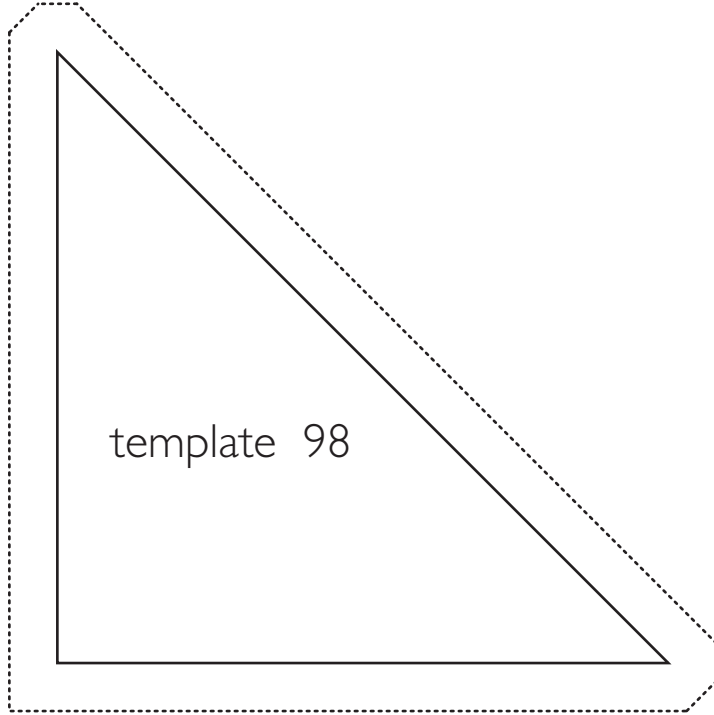

template 98

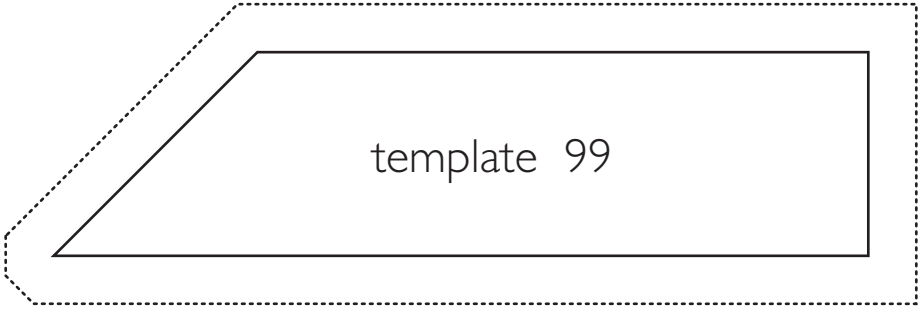

template 99

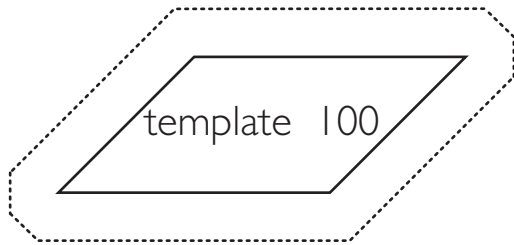

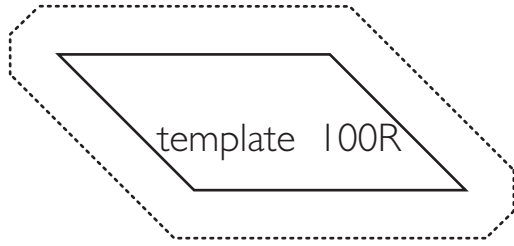



template 101

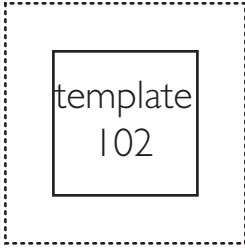



template 103

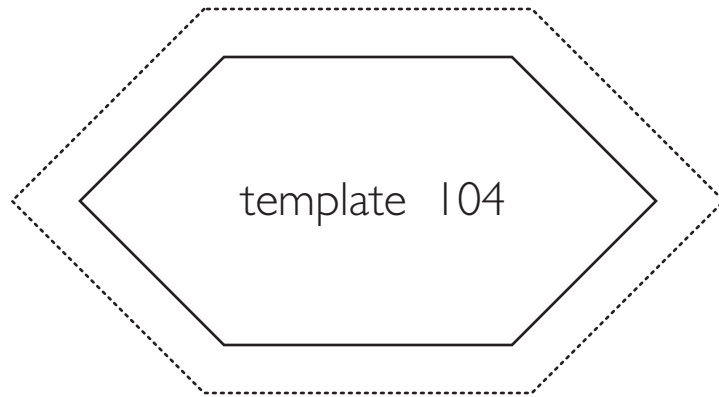

$\frac{3}{16}$ " turn under allowance

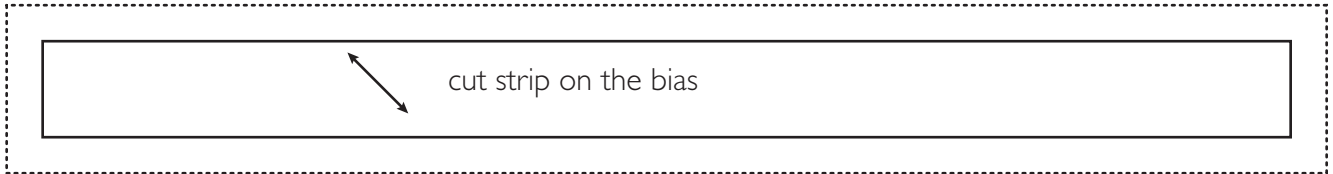

Template for hand-appliqué handle on block #35 Flower Basket. Cut one.

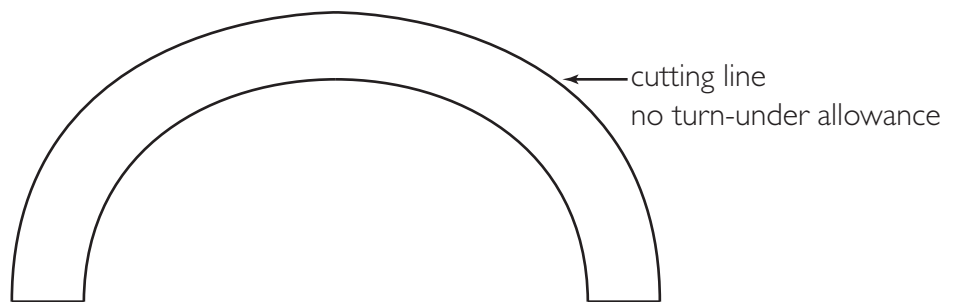

Template for machine-appliqué on block #35 Flower Basket. Cut one.

template 106